

# MaxMotion

## PERFORMANCE DATA SHEET

Catalogue #: **MKR-124W**

HP	kW	Voltage	S.F. @ 60Hz	EFF.	P.F.	Frame	Design	L.R. Amps
0,5	0,37	575	1,15	72,0%	0,650	56	B	5

60 Hz								
FLA							Code	F.L. RPM
208	230	416	460	480	575	600		
/	/	/	/	/	0,8	0	L	1750

50 Hz								
FLA			S.F. @ 50Hz	Efficiency	Power Factor	Code	F.L. RPM	
190	380	415						
/	/	/	/	/	/	/	/	

Wgt. Lbs	PH	Duty	Insul. Class	Amb.	Elevation	Temp. Rise° C
23	3	Cont.	F	40°C	1000M (3300 Ft)	39

% Efficiency		% Power Factor		Torque		Winding Resist. Ω	Safe Cold Start (Secs)
Full Load:	72,0%	Full Load:	0,65	Full Load Ft/Lbs	1,5		
3/4 Load:	67,6%	3/4 Load:	0,59	Locked Rotor %	250		
1/2 Load:	55,5%	1/2 Load:	0,52	Break Down %	330	/	12

Rotor Inertia Wk2 Lb-Ft2	Max Load Inertia Wk2 Lb-Ft2	Shaft Material	Frame Material	DE Bracket Type	ODE Bracket Type	Enclosure	NEMA Rating	Lead Wire Size
/	/	Stainless Steel				ODP	IP23	0

Ball Bearings		Grease	Mount Type	Orientation	Paint	Sound Pressure @ 3FT	Sound Power
DE	ODE						
6205	6203	Sealed Bearings	Rigid	Horizontal	Black	/	/

Inverter Duty. Motor meets MG1 parts 31.4.4.2	Constant Torque Range	Variable Torque Range	Constant HP RPM
	2:1	10:1	/

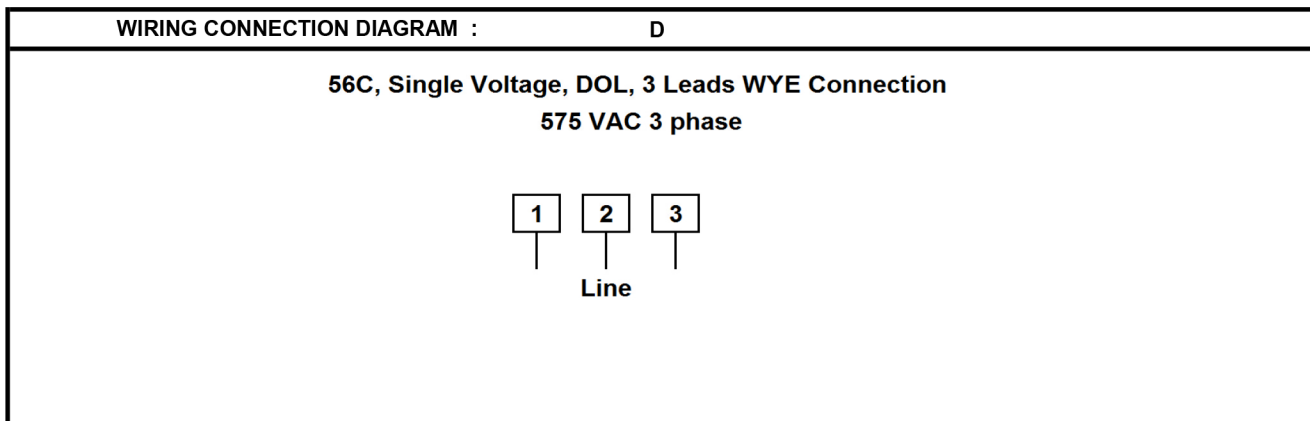

# MaxMotion

Date: 04/10/2018  
 Customer: \_\_\_\_\_  
 Contact: \_\_\_\_\_  
 Submittee: J.C. Lavallée

Catalogue #: **MKR-124W**

HP	VAC	RPM	Enclosure	Frame	Frequency	Design	Poles	LR Code Letter	Insulation Class	Temp. Rise °C
0,5	575	1750	ODP	56	60	B	4	L	F	39

  

Load %	0%	25%	50%	75%	100%	125%	150%
Amps	0,57	0,61	0,65	0,70	0,80	1,00	1,20
Torq ft/lbs	0	0,37	0,74	1,12	1,50	1,89	2,28
RPM	0	1787,5	1775	1762,5	1750	1737,5	1725
Eff	0	34,22	55,51	67,63	72,00	70,61	68,60
PF	0	45,0	52	59	65,0	66,3	68,3

  

	Locked Rotor	Pull-Up	Breakdown	Rated Load	Idle	Duty	S. F.	Ambient	Elevation	dBA @ 1M
Speed (RPM)	0	756	1440	1750	1800	Continuous	1,15	40°C	3,300 ft	/
Current (Amps)	5	4,3	3,0	0,8	0,568	VFD Rating: Meets MG1 parts 31.4.4.2				
Torque (ft-lbs)	3,75	3,19	4,95	1,50	0,0	C.T.	2:1	V.T.	10:1	

Motor Speed Data

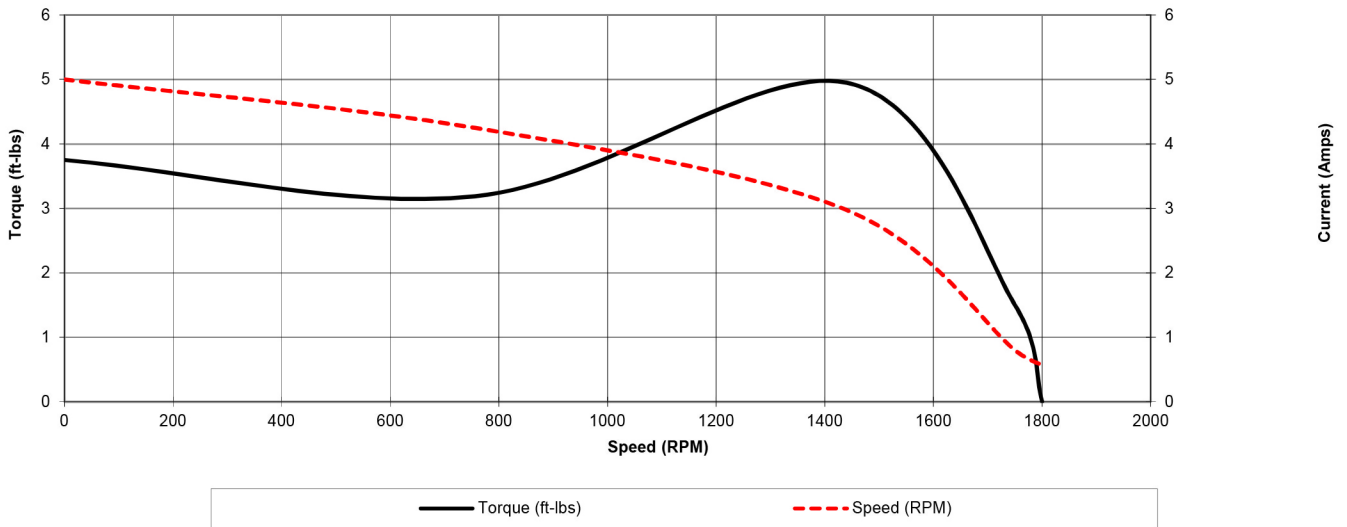

Motor Load Data

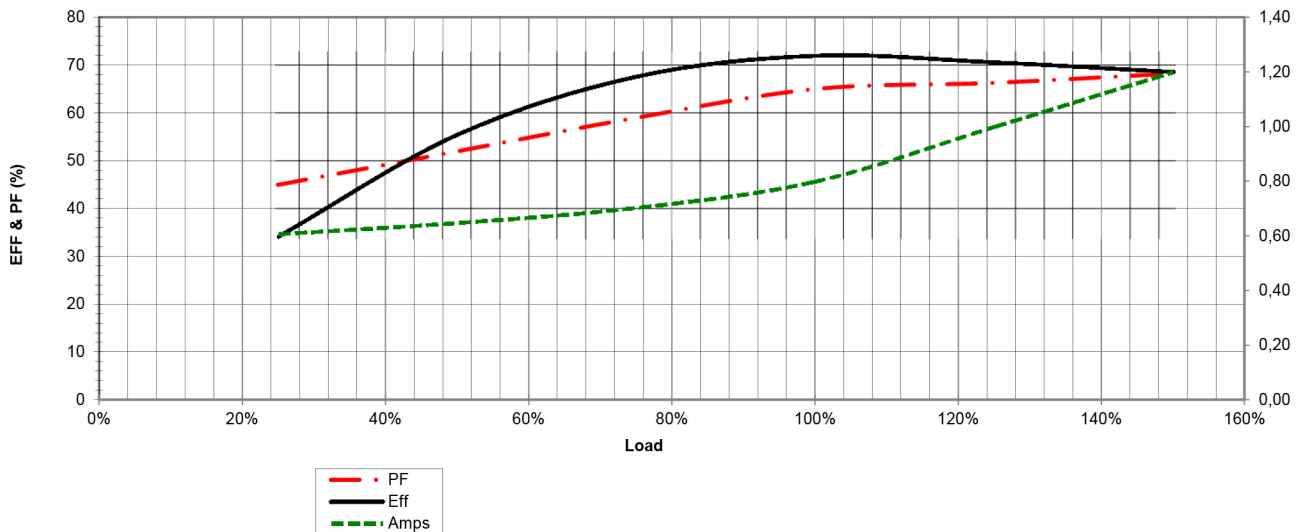

Date: 04/10/2018  
 Customer: \_\_\_\_\_  
 Contact: \_\_\_\_\_  
 Submittee: J.C. Lavallée

Catalogue #: **MKR-124W**

HP	VAC	RPM	Enclosure	Frame	Frequency	Design	Poles	LR Code Letter	Insulation Class	Temp. Rise °C
0,5	575	1750	ODP	56	60	B	4	L	F	39

	0Hz	6Hz	15Hz	30Hz	45Hz	60Hz	75Hz	90Hz	105Hz	120Hz
Amps	0,8	0,8	0,8	0,8	0,8	0,8	0,8	0,8	0,8	0,8
RPM	0	175	437,5	875	1312,5	1750	2187,5	2625	3062,5	3500
Torq ft.lb	1,20	1,20	1,50	1,50	1,50	1,50	1,20	1,00	0,86	0,75
Peak Tq ft.lb	1,99	3,98	3,98	3,98	3,98	3,98	3,18	2,65	2,27	1,99
HP	0	0,0	0,1	0,3	0,4	0,5	0,5	0,5	0,5	0,5

	Locked Rotor	Pull-Up	Breakdown	Rated Load	Idle	Duty	S. F.	Ambient	Elevation	dBa @ 1M
Speed (RPM)	0,0	756	1440	1750	1800	Continuous	1,15	40°C	3,300 ft	/
Current (Amps)	5,0	4,3	3,0	0,8	0,6	VFD Rating: Meets MG1 parts 31.4.4.2				
Torque (ft-lbs)	3,8	3,2	5,0	1,5	0,0					

Motor Speed Data

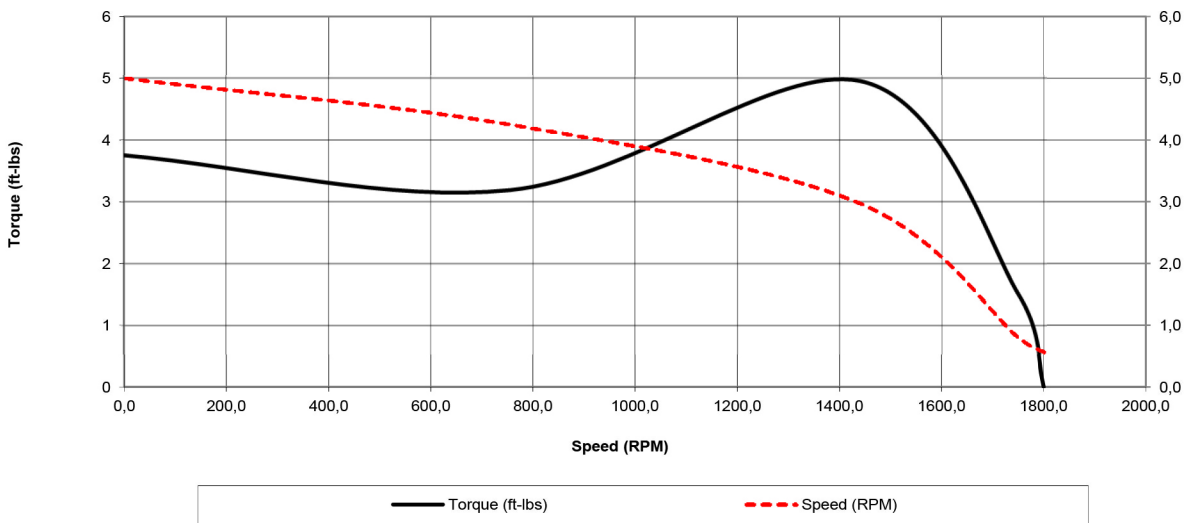

Motor Torque Capability vs RPM

